

TECHNICAL INFORMATION

ANTI - UPLIFT CASTOR AA0002

TIS17032-



ARTICLE	DESCRIPTION	WEIGHT (kg)	MATERIAL	SURFACE FINISH
AA0002	ANTI UPLIFT CASTORS	15.14	STEEL (GRADE VARIES)	HOT DIP GALVANIZED

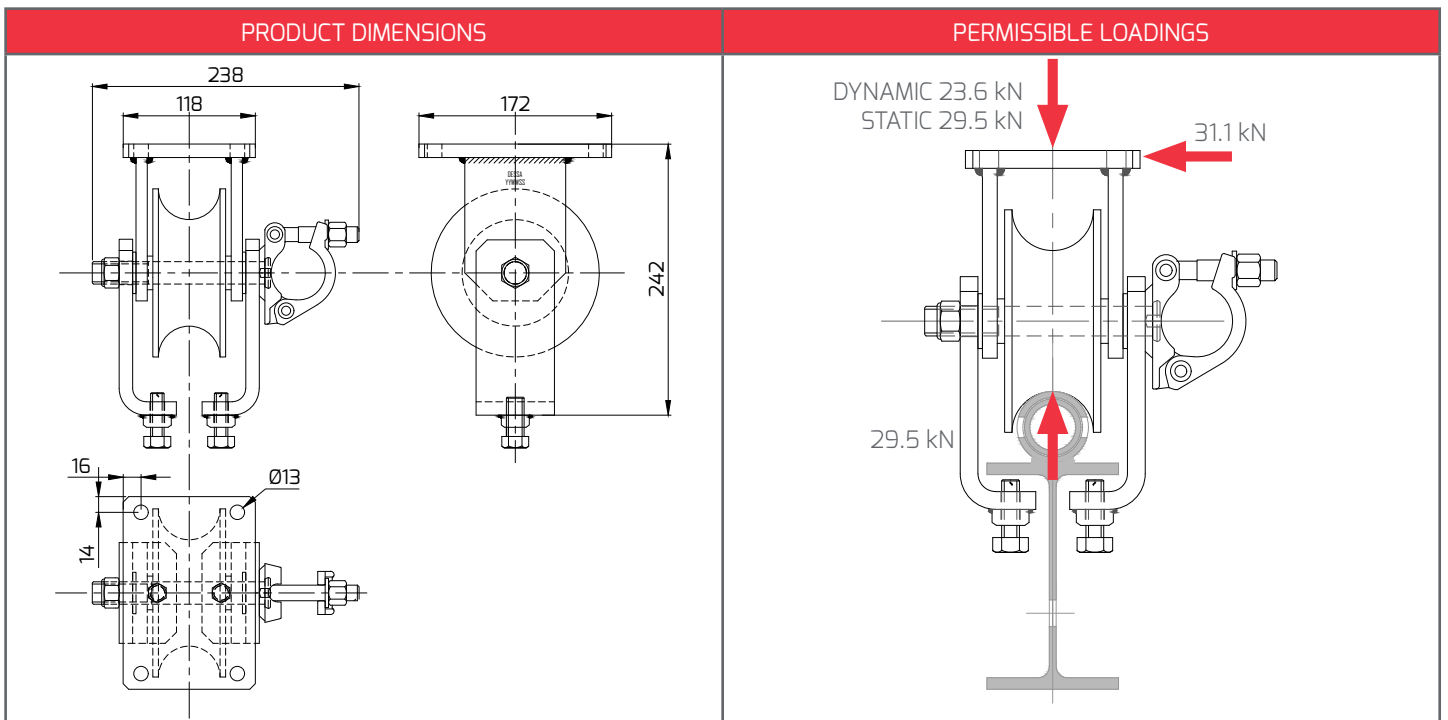

USED WITH

TRAX UB RUNWAY, ALL CASTOR TOP PLATE CONNECTIONS

The information provided is based on prevailing legislation and/or testing. DESSA Ltd reserves the right to make technical changes, users should ensure that only current revisions of this Technical Information Sheet are used. The published data refers to original genuine DESSA materials only. © DESSA Limited. No unauthorised use, copy or disclosure is to be made.