

# RANGER™ STAIR

## USER GUIDE



## Foreword

DESSA offers efficient lightweight temporary roofing, encapsulation solutions, aluminium lattice girders and safety products. DESSA's unique and distinctive aluminium solutions are suitable for not only grandstands, stages and events but also public utility works, local authorities, government buildings, historic buildings, highways, bridges and industrial market sectors.

From a choice of roofing solutions and general purpose lattice girders providing unrivalled cost to strength ratio, to high capacity lattice girders complete with a dedicated bracing system, we provide the industry with an ever widening range of cost effective products along with extensive after sales support to the highest professional standards.

At DESSA we develop innovative and practical solutions for the support, access and weather protection industries. All of our designs are technically proven and are registered with protected design rights meaning only DESSA can offer superior solutions through our products.

Our senior management team at DESSA offer considerable experience in the fields of contracting, engineering, manufacture and customer service. Having introduced a number of class leading products into the UK market and we have worked closely with a number of key clients in developing bespoke solutions to their problems which we manufacture on an exclusive basis.

## RANGER™ Stair Introduction

The DESSA RANGER™ Stair is a simple self-contained product which is easy to store packed flat and can be collected or delivered on small vehicles including vans for the smaller models. Product selection is easy, depending only on the range of lift heights required, and users have the assurance that all models, in all possible positions, are fully compliant with EN 12811-1 (Temporary works equipment – Scaffolds). Non-scaffolding users will find the RANGER™ Stair easy to use, with a first class result achievable with no special training.

# Contents

1.0	Introduction .....	1
2.0	Component Recognition.....	1
2.1	Core Elements.....	1
2.2	Guardrails.....	2
2.3	Connectors.....	2
3.0	Assembly .....	3
3.1	Basic Assembly .....	3
3.2	Alternative Connector Applications .....	6
3.2.1	48.3mm Tube .....	6
3.2.2	Horizontal Surfaces .....	6
3.2.3	Timber Joists.....	6
4.0	Technical Data.....	7
4.1	Model Information .....	7
4.1.1	Stair Assemblies.....	7
4.1.2	Guardrail Units.....	7
4.1.3	Stair Guardrail Requirements.....	7
4.1.4	Connectors .....	7
4.2	Model Geometry.....	8
4.2.1	Model Application Range.....	8
4.2.2	Tread Details .....	9
4.3	Structural Performance Data .....	10
4.4	Typical Layouts.....	10
4.4.1	Tube and fitting scaffold, alternating direction, external, parallel.....	10
4.4.2	Tube and fitting scaffold, alternating direction, external, perpendicular .....	11
5.0	Specific Risk and Hazards to Health .....	12
5.1	During Installation.....	12
5.2	Post-Installation .....	12
6.0	Inspection and Maintenance .....	12
6.1	Inspection.....	12
6.2	Maintenance .....	12

## 1.0 Introduction

The DESSA RANGER™ Stair is a range of self-contained, pre-assembled aluminium stair units, flat packed, which automatically adjust to a wide range of lift heights, making them ideal for use in tube and fitting scaffolds along with other applications. The DESSA RANGER™ Stair is fully compliant with BS EN12811 for all possible configurations.

## 2.0 Component Recognition

### 2.1 Core Elements

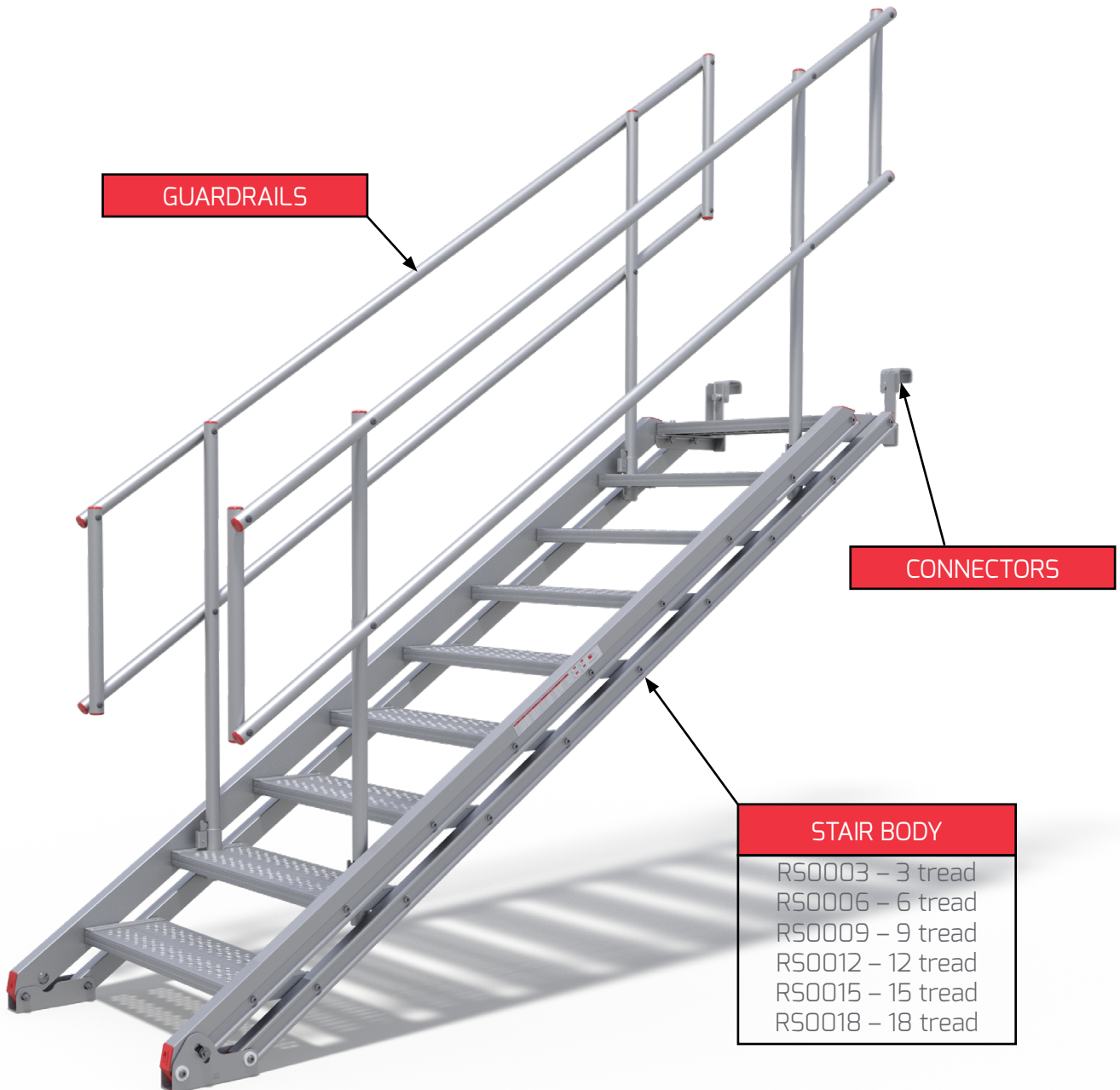

## 2.2 Guardrails

The DESSA RANGER™ Stair guardrails are available in two lengths to correspond to the stair body being used. Instructions of which guardrails are to be used with each stair body can be found in Section 4.1.3 of this document.

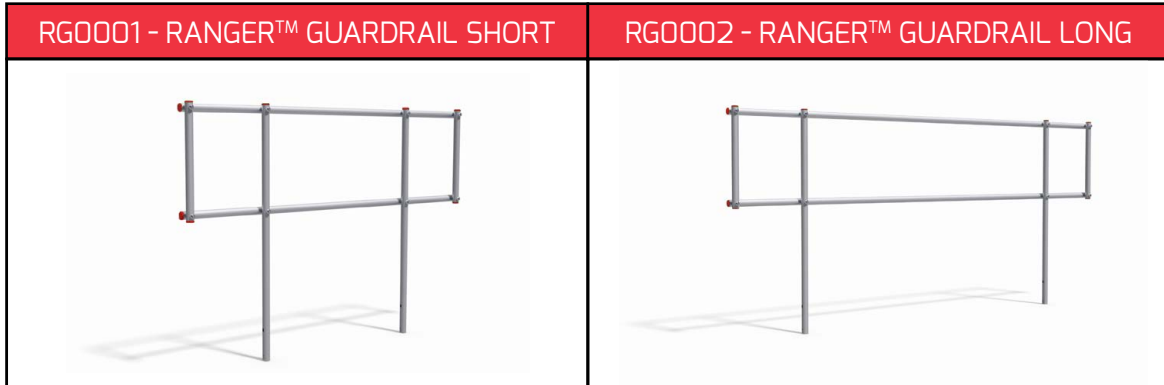

## 2.3 Connectors

The DESSA RANGER™ Stair bodies include the tube connector brackets RBO011 and RBO012. There are also interchangeable brackets available for when the DESSA RANGER™ Stair is used for alternative applications.

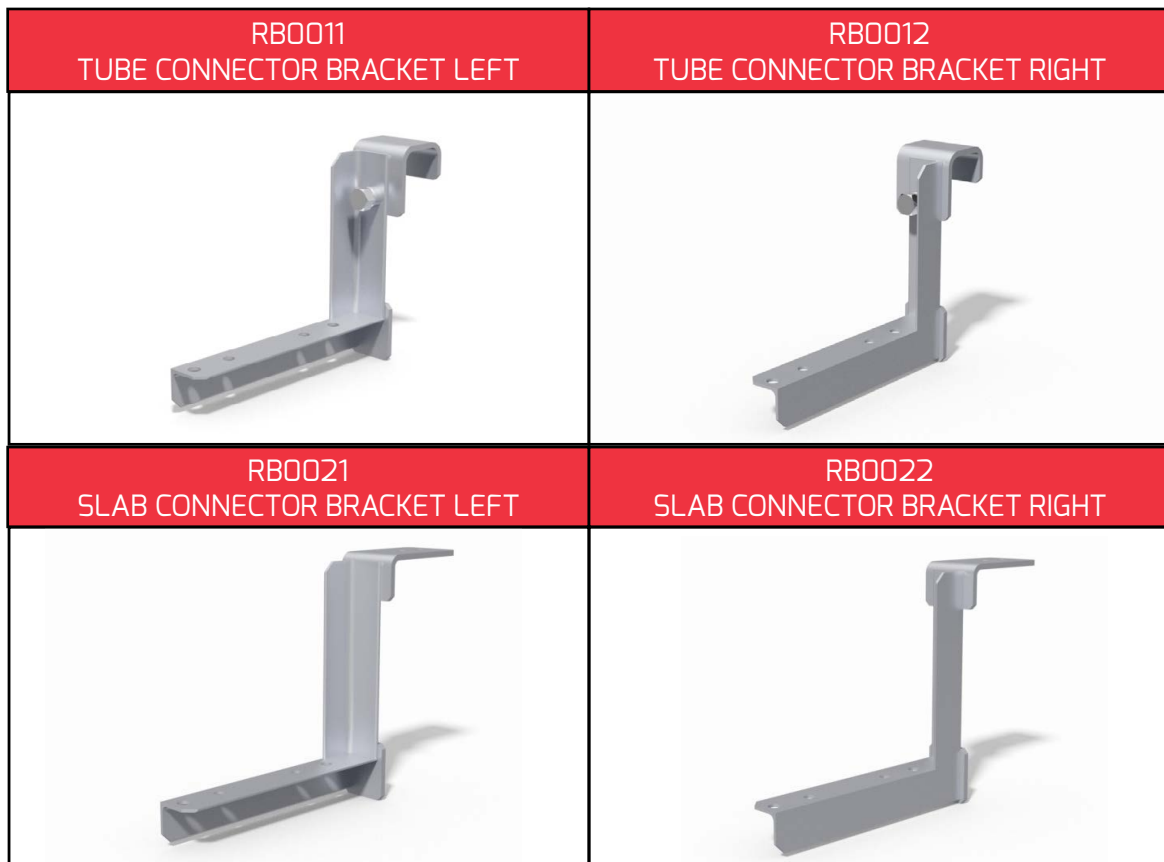

## 3.0 Assembly

### 3.1 Basic Assembly

Step #1 – Insert **guardrail assemblies** into the guardrail sockets. The **built-in spring retainers** will lock these in place.

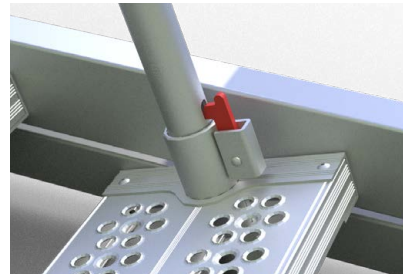
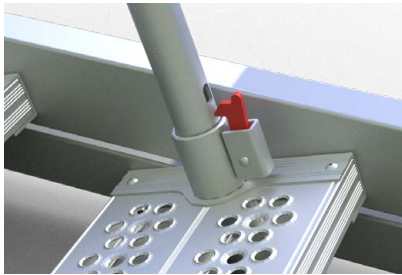
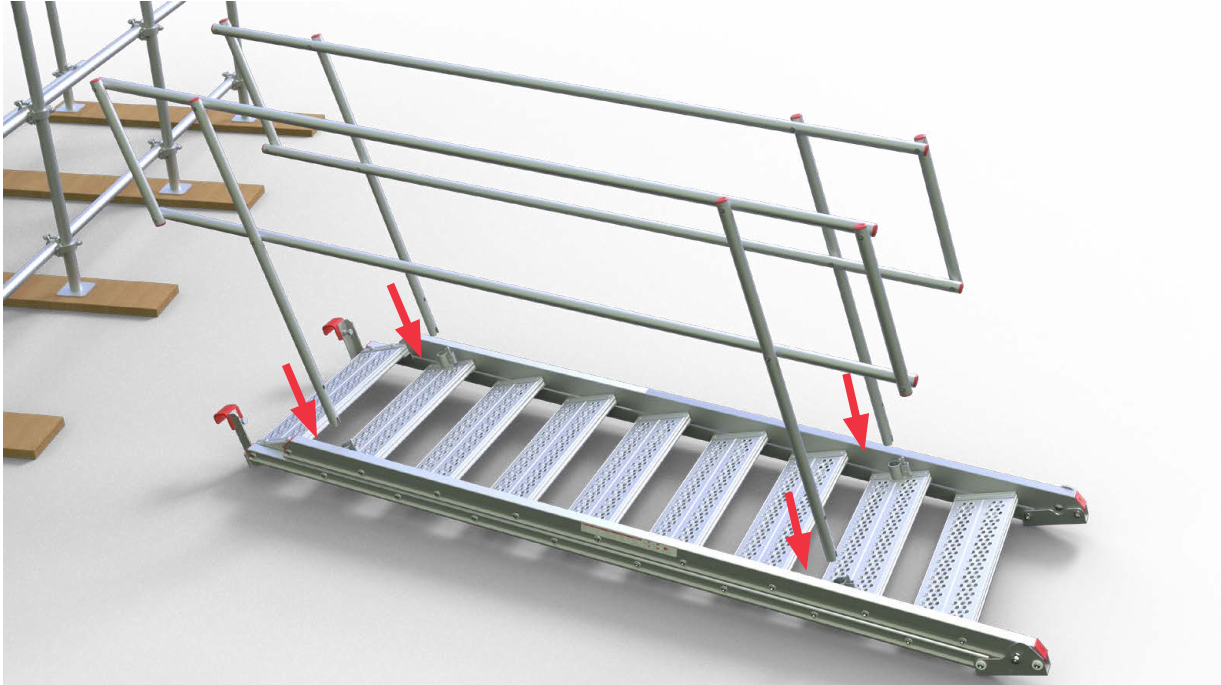

Step #2 – Engage RANGER™ Stair assembly to tube using **connector brackets**.

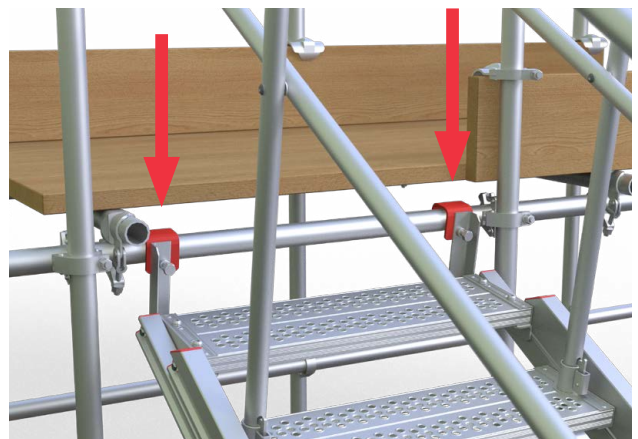

Step #3 – Articulate guardrails to find the optimal angle and level treads.



Step #4 – Lock the stair by engaging **locking nut** into footplate, using a standard scaffold spanner.

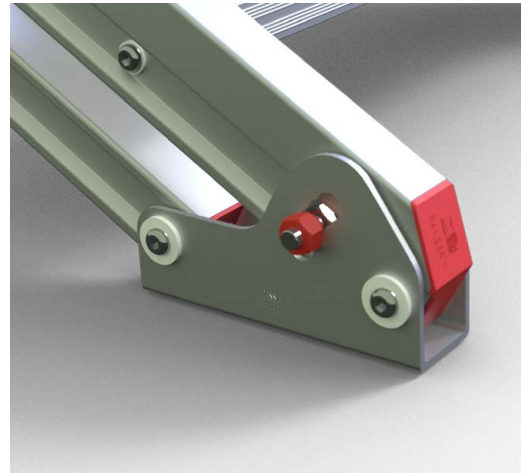
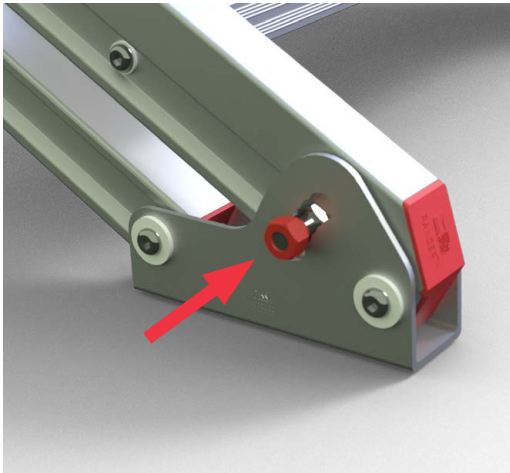

Ensure nut shoulder locates into one of the preformed holes in the footplate.

Step #5 – From a safe working level, tighten the integrated **anti-uplift bolts** on the underside of the tube connector brackets, using a standard scaffold spanner.

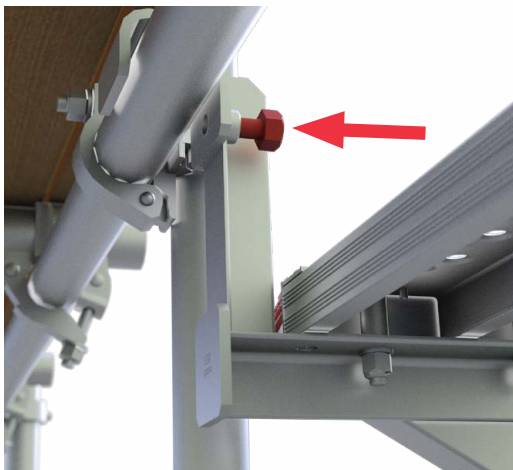

Do not overtighten the anti-uplift bolts.



## 3.2 Alternative Connector Applications

### 3.2.1 48.3mm Tube

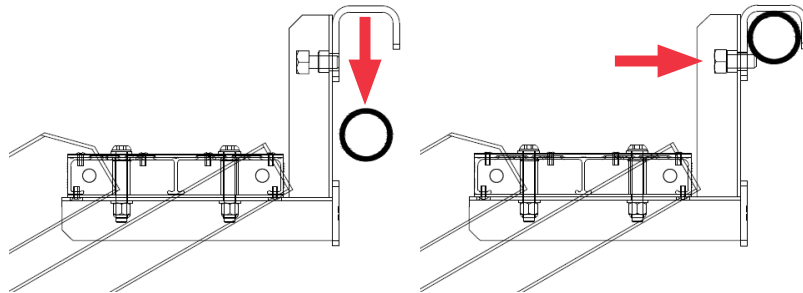

Use brackets RB0011 and RB0012 to attach the DESSA RANGER™ Stair to 48.3mm scaffold tubes. The brackets can be secured to the tube using the integrated bolt fixing, thereby preventing uplift.

### 3.2.2 Horizontal Surfaces

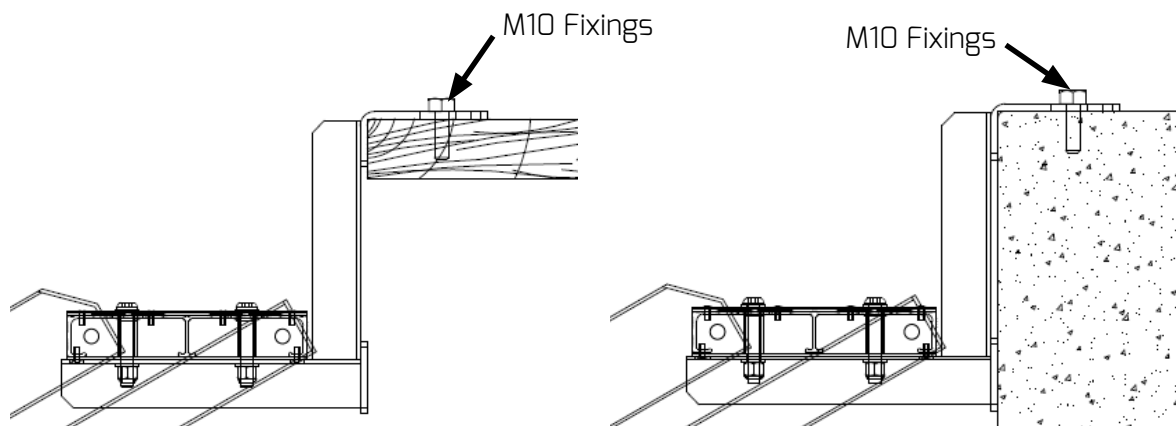

For horizontal surfaces use brackets RB0021 and RB0022 with M10 fixings to secure.

### 3.2.3 Timber Joists

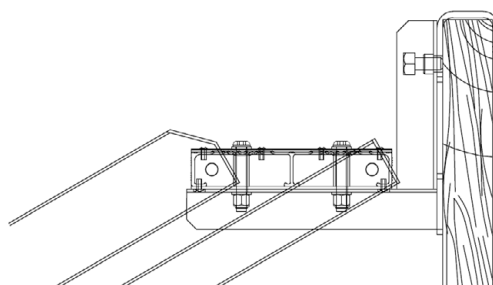

The RB0011 and RB0012 brackets are also to be used with timber joists up to 50mm in width. The anti-uplift bolt can be used to secure the stair by tightening lightly into the timber joist.

## 4.0 Technical Data

### 4.1 Model Information

#### 4.1.1 Stair Assemblies

PART NUMBER	DESCRIPTION	WEIGHT (KG)
RS0003	RANGER™ Stair, 3 Tread	18.49
RS0006	RANGER™ Stair, 6 Tread	29.66
RS0009	RANGER™ Stair, 9 Tread	40.71
RS0012	RANGER™ Stair, 12 Tread	51.92
RS0015	RANGER™ Stair, 15 Tread	62.91
RS0018	RANGER™ Stair, 18 Tread	87.80

#### 4.1.2 Guardrail Units

PART NUMBER	DESCRIPTION	WEIGHT (KG)
RG0001	RANGER™ Guardrail Short	5.9
RG0002	RANGER™ Guardrail Long	7.3

#### 4.1.3 Stair Guardrail Requirements

PART NUMBER	DESCRIPTION	GUARDRAIL SHORT RG0001	GUARDRAIL LONG RG0002
RS0003	RANGER™ STAIR, 3 Tread	-	-
RS0006	RANGER™ STAIR, 6 Tread	2	-
RS0009	RANGER™ STAIR, 9 Tread	-	2
RS0012	RANGER™ STAIR, 12 Tread	4	-
RS0015	RANGER™ STAIR, 15 Tread	2	2
RS0018	RANGER™ STAIR, 18 Tread	-	4

#### 4.1.4 Connectors

PART NUMBER	DESCRIPTION	WEIGHT (KG)
RB0011	Tube Connector Left	1.36
RB0012	Tube Connector Right	1.36
RB0021	Slab Connector Left	1.38
RB0022	Slab Connector Right	1.38

## 4.2 Model Geometry

### 4.2.1 Model Application Range

PART NUMBER	MINIMUM HEIGHT (MM)	MAXIMUM HEIGHT (MM)
RS0003	557	783
RS0006	985	1457
RS0009	1412	2130
RS0012	1840	2804
RS0015	2267	3478
RS0018	2696	4152

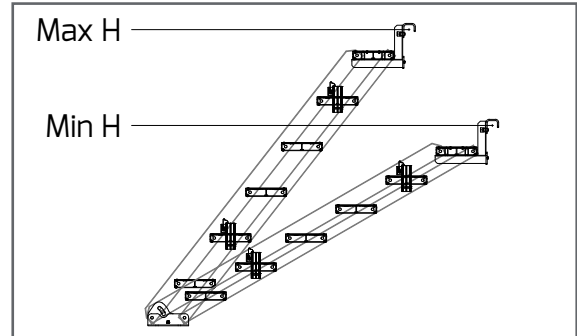

Note: the above table relates to application range when using tube connector brackets RB0011 and RB0012 only. The height measurement is taken to the centre of the scaffold tube to which the connector bracket engages.

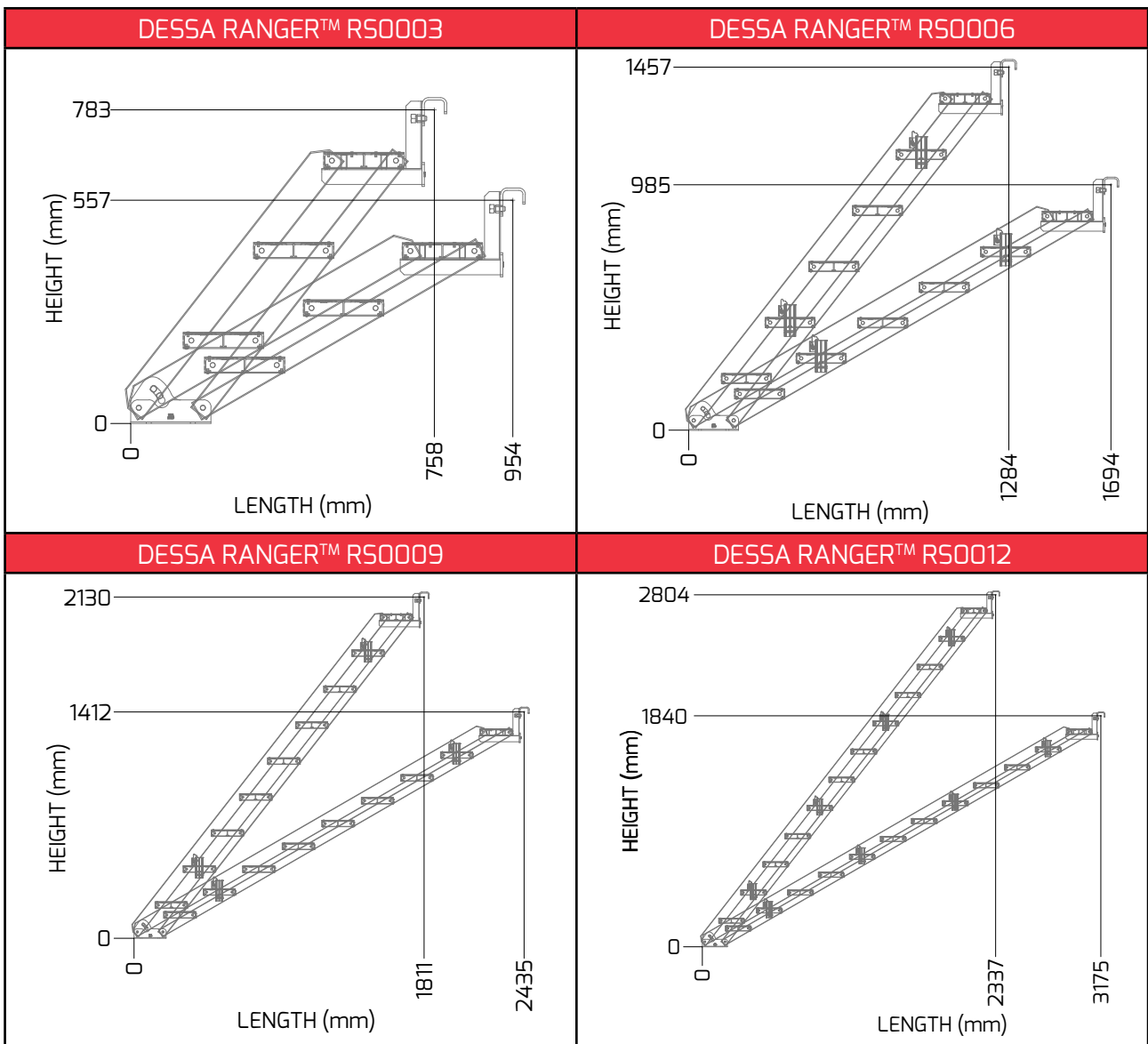

DESSA RANGER™ RS0015

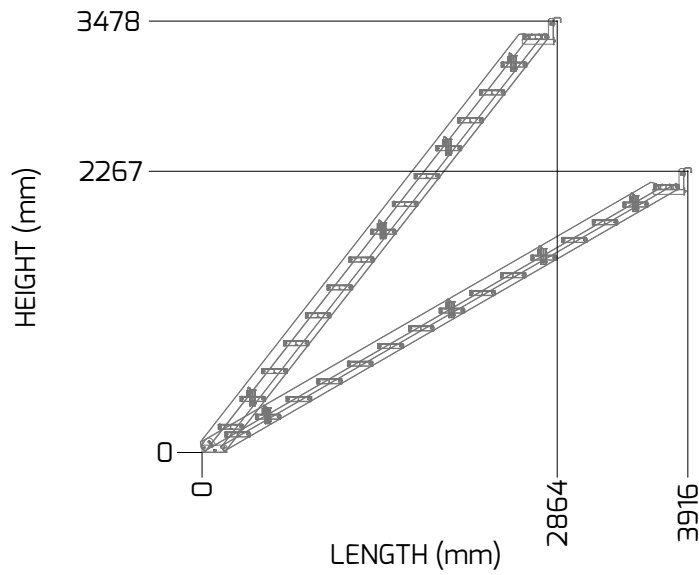

DESSA RANGER™ RS0018

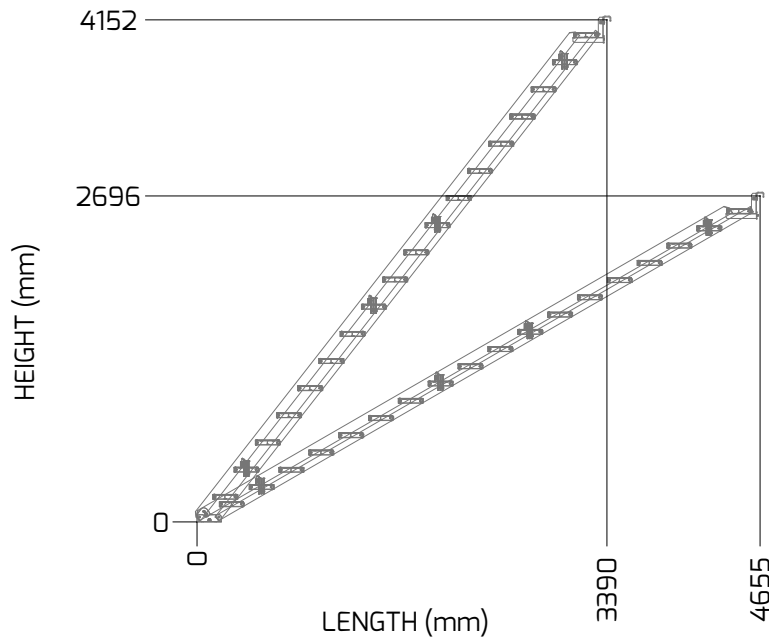

4.2.2 Tread Details

PART NUMBER	NUMBER OF TREADS	TREAD WIDTH (MM)
RS0003	3	720
RS0006	6	720
RS0009	9	720
RS0012	12	720
RS0015	15	720
RS0018	18	720

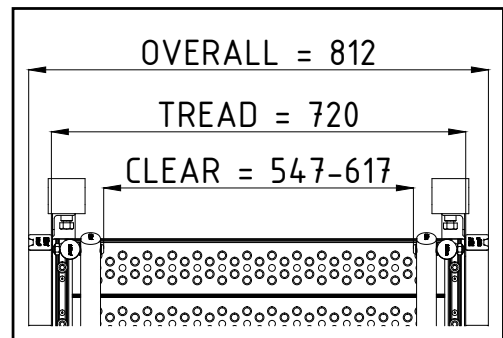

### 4.3 Structural Performance Data

MODEL NUMBER	UNIFORMLY DISTRIBUTED LOAD (kN/m <sup>2</sup> )	POINT LOAD (kN)
RS0003	>1.5	1.5
RS0006	>1.5	1.5
RS0009	>1.5	1.5
RS0012	>1.5	1.5
RS0015	=1.5	1.5
RS0018	=1.5	1.5

**NOTE: UNIFORMLY DISTRIBUTED LOAD CASE ASSUMES EVERY TREAD LOADED SIMULTANEOUSLY. POINT LOAD CASE IS MAXIMUM PER TREAD.**

### 4.4 Typical Layouts

#### 4.4.1 Tube and fitting scaffold, alternating direction, external, parallel

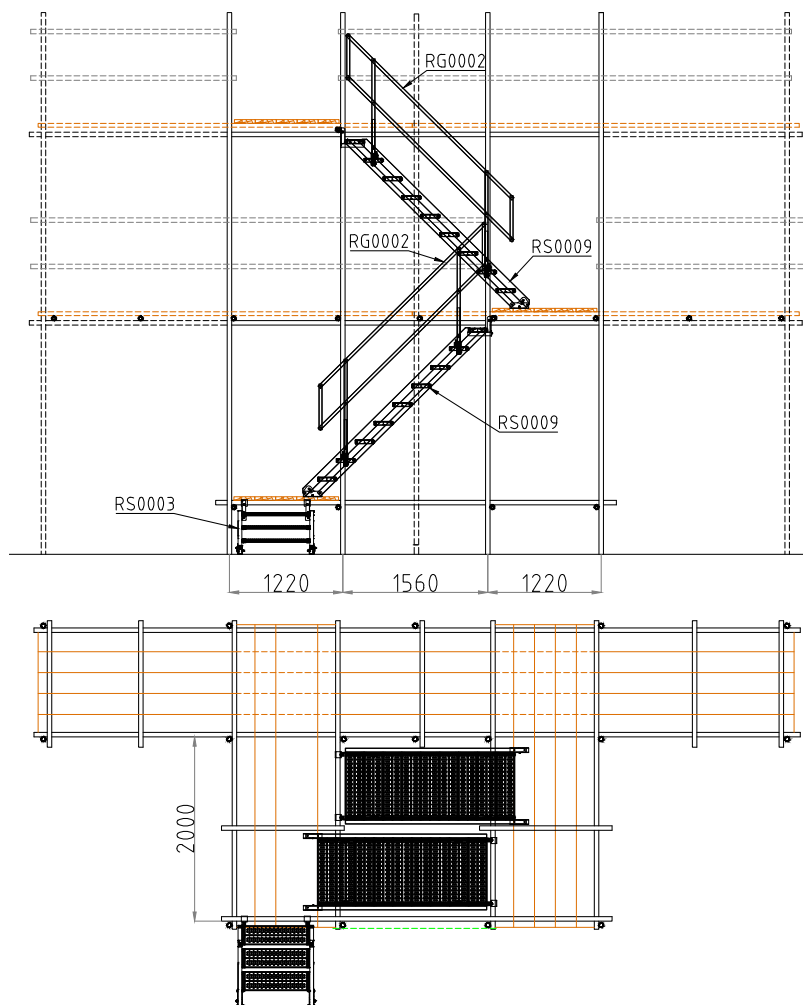

#### 4.4.2 Tube and fitting scaffold, alternating direction, external, perpendicular

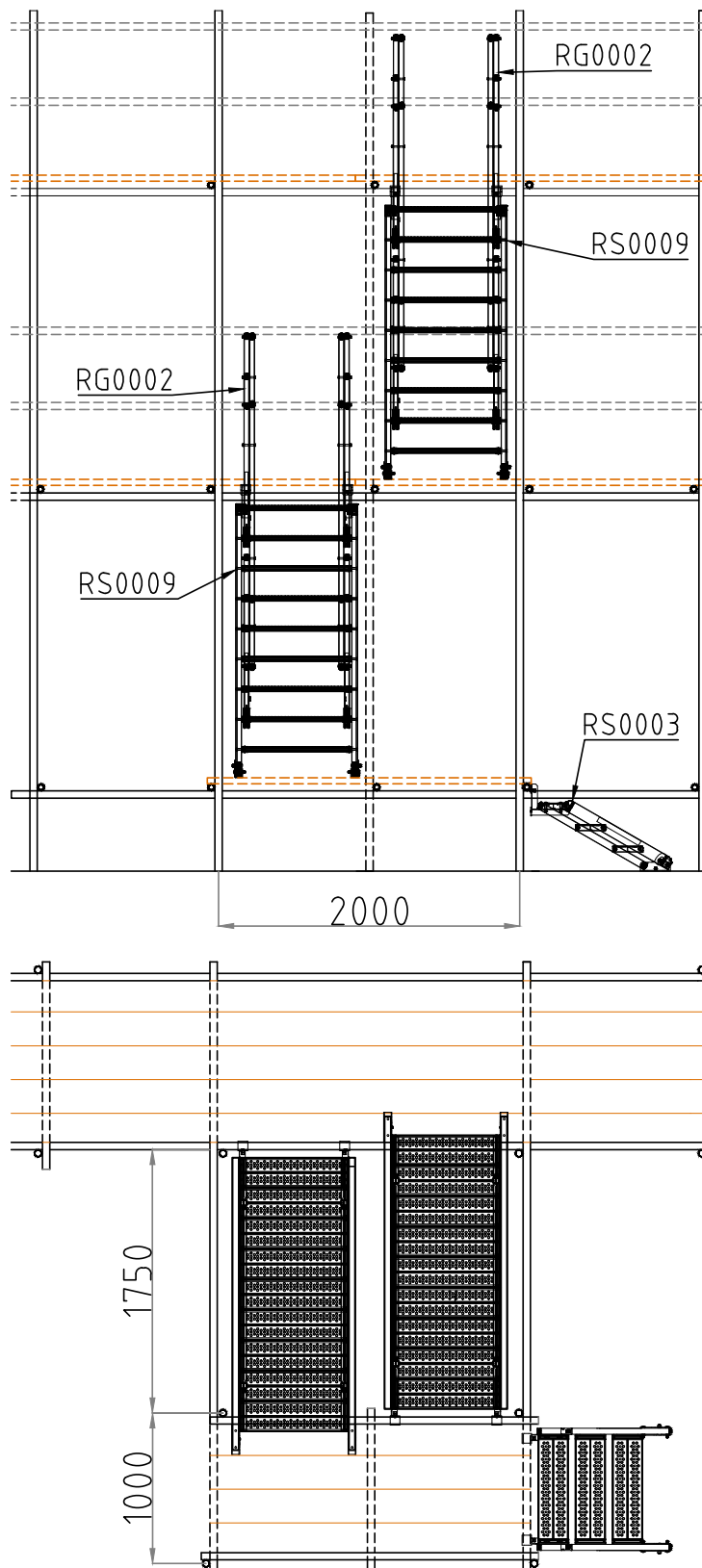

## 5.0 Specific Risk and Hazards to Health

### 5.1 During Installation

- Ensure that appropriate PPE is worn at all times during the installation process. As a minimum, this will entail gloves, steel toe cap boots and a hard hat.
- The manual handling, lifting and placement of the RANGER™ Stair units from RS0006 upwards require a minimum of two operatives.
- Avoid placement of objects between the treads at the tread/stringer intersection whilst the stair is being adjusted as this gap is variable whilst adjustments are being made.
- Ensure that all guardrails and toe boards are installed and secured safely at each landing position.

### 5.2 Post-Installation

- Ensure at least one hand is placed on the guardrails at all times whilst the RANGER™ Stair units are being traversed.
- Avoid running whilst entering, traversing and exiting the RANGER™ Stair units.
- Ensure that the RANGER™ stair treads are kept free from debris and loose materials at all times.
- Materials are not to be stored on the RANGER™ stair units.
- Ensure that the RANGER™ Stair treads are kept free from grease or oil spillages.
- Ensure that the locking stays are engaged at all times and are not tampered with.
- Ensure that the connector brackets are firmly engaged.
- Some corrosive environments and extreme temperatures may affect the performance and durability of the alloy stairway. Contact DESSA's technical team for advice if these are suspected to be influencing the DESSA RANGER™ Stair.

## 6.0 Inspection and Maintenance

### 6.1 Inspection

The following list requires inspection on a weekly basis, or prior to each installation of the DESSA RANGER™ Stair:

- Check all nuts and bolts are in position and tight.
- Check all bolts for looseness.
- Check all treads for damage.
- Check all stringers for damage.
- Check connector brackets for damage.
- Check guard rail sockets for damage.

### 6.2 Maintenance

The DESSA RANGER™ Stairs are a fully bolted construction and therefore any routine maintenance is straightforward using the minimum tools. Tools required: 12mm spanner, 8mm allen key.



DESSA  
SCAFFOLD  
PRODUCTS  
TECHNICAL  
SERVICES

DESSA LIMITED  
Unit 25 Little End Road, Eaton Socon, St. Neots, Cambridgeshire, PE19 8JH - United Kingdom  
Tel +44 (0)1480 475297 - Fax +44(0)1480 215378 - Email: [info@altrad-dessa.com](mailto:info@altrad-dessa.com)  
[www.altrad-dessa.com](http://www.altrad-dessa.com)